

# FloorHeat<sup>o</sup>

---



## **PRE-ASSEMBLED RADIANT CONTROL PANEL INSTALLATION MANUAL**

## Thank you

for purchasing this radiant control panel assembly. Following are some important notes that will make the installation successful.

- Read through the entire manual before starting installation
- Do NOT plug in the power cord until the panel is installed, connected, and the fluid has been filled.
- If there has been damage in shipment, please call 888-265-5455 for troubleshooting, returns, and replacement parts. Do NOT return the panel to the store.
- Installation must be performed by a qualified person in accordance with national and local codes and standards.
- All electrical connections must be installed by a licensed electrician.
- This generic manual covers several different versions of control panels. Please refer to the plumbing schematic in the appendix to specific plumbing information.
- *Failure to follow these instructions may result in fire, electrical shock, property damage, personal injury or death.*

# INSTALLATION

## 1. Planning the installation.

The control panel should be mounted on a wall or permanent vertical surface near the boiler for convenient plumbing and wiring. It should be mounted at a convenient height to ease installation and maintenance.

## 2. Panel Mounting.

Once the location has been determined, drill (2)  $\frac{1}{4}$ " diameter holes on each of the four panel mounting flanges. Install a 1x wood cleat, 28" long, to the mounting surface where the top panel flange will be mounted. Make sure the cleat is level. Using the cleat to help support the panel, install the appropriate mounting screws. The screws should be at least 1-1/2" long.

## 3. Boiler supply and return lines.

Using 1" type L copper tubing, route the supply and return lines to the boiler. Refer to the appropriate panel schematic in the appendix and the boiler manufacture's plumbing schematic for specific information. As a general guideline maintain the shortest possible plumbing distance between the panel and boiler while minimizing the use of the 90 degree fittings. Every fitting increases flow resistance, reducing heat transfer. Also, all tubing runs must be properly supported. Use Uni-Strut channels and clamps or equivalent for tube support. Note additional plumbing devices may be needed such as a low water cut off, circulator, ball valves, etc. Refer to the boiler plumbing schematic.

#### **4. Manifold transmission lines.**

Using  $\frac{3}{4}$ " type L copper tubing or  $\frac{3}{4}$ " oxygen barrier PEX tubing, route the transmission lines from the control panel to the zone manifold(s). Referring to the appropriate panel schematic in the appendix, note the location of the supply and return lines. Customarily, the upper zone manifold is the return to bring any trapped air back to the control for purging. Use the same guideline for tube routing as the boiler lines, minimize line lengths, minimize 90 degree fittings, and properly support lines.

#### **5. Water makeup line.**

**NOTE:**

The standard control panels are designed for installations where the fluid temperatures should never go below freezing. For seasonal or snow melt installations, different control panels are needed for the use of anti-freeze solutions. The best fluid for radiant heating systems is clean water. The water, however, does need to have a minimum pH of 5 and low hardness. Treat water if necessary before proceeding.

Using  $\frac{1}{2}$ " type L or M copper tubing, connect the "cold water supply" line on the control panel to the suitable clean water source. Do NOT turn on water yet.

#### **6. Check expansion tank pressure.**

Remove the plastic cap on the expansion tank, and using a standard tire pressure gauge, check tank pressure. It should be about 10 to 12 psi. Add pressure if necessary.

The tank pressure should be checked **annually** for proper system operation. This is done by closing the expansion tank ball valve, removing drain cap, attaching a drain hose and opening the drain valve. A small amount of water/pressure will come out. This isolates the tank from the system and removes any residual system pressure. Check the tank pressure and add pressure if necessary. Close drain valve, disconnect hose, replace cap, and open expansion ball valve. The system is ready to use.

## **7. Initial system fill.**

Open all of the ball valves to the zone manifolds and boiler. There is a little brass cap on the top of the air eliminator on the control panel. Loosen the cap slightly to allow air in the system to be purged. Open the water supply ball valves. This operation will fill most of the system with water and should take only a few minutes. Once the system pressure on the control panel is about 15 to 20 psi, the pressure reducing valve will automatically shut off the water supply. **Shut off the water supply ball valve and close the air eliminator vent cap.**

## **8. System purge.**

It is important that all air is removed from the system before start up. Air in the system can cause corrosion of components, noise, and cold zones. A properly purged system will be almost silent in operation. Referring to the appropriate panel schematic in the appendix, there are two purge/fill diagrams in the upper right hand corner. These diagrams show the proper ball valve orientation to first purge the low temperature zone manifold side and then purge the boiler side last.

A simple setup to use for system purge is a high-flow submersible pump, 5-gallon bucket, (2) 1" hoses about 6' long, and the necessary fittings. Plumb the submersible pump discharge with one of the 1" hoses into the in ball drain port as noted on the schematic. Plumb the second 1" hose to the out ball drain port as

noted on the schematic. This second hose returns to the 5-gallon bucket. With the pump in the bucket, fill the bucket with clean water.

Each of the ball drain valves have two ball valves. The ball valve where the hose attaches, simply opens and closes the line. The second ball is actually a 3-way valve, which can direct water flow straight through or one direction or the other. The ball valve handle decal indicates flow direction.

To purge the low temperature side, orient the 3-way valve as shown on the purge/fill diagram. Plug in the submersible pump and slowly open both of the inlet ball valves on the ball drain valves. Water should be now flowing through the system and returning to the 5-gallon bucket. The return water will have a considerable amount air coming out as well. Continue running the pump until most of the air is removed. This may be several minutes. Make sure the water level in the bucket does not get too low and add water as needed.

Now each zone and loop must to purged separately to insure all air is removed. Slowly shut the ball valves to all the zone manifolds except for one. Now all the water flow should be going through the one open zone manifold. At the zone supply manifold, slowly close all the loop-ball valves on the supply except one loop. Now all water flow will be flowing through a single loop. Continue running the pump until the return water is free of air bubbles. Slowly open the next loop ball valve and close the first loop ball valve. This method of opening and closing loop ball valves isolates each loop forcing all air from the system. Once a loop manifold is complete, open all loop ball valves. At the control panel slowly open the next zone loop ball valve and close the previous. Proceed as before opening and closing loop zones at the supply manifold until all air is eliminated. When all zones and loops have been purged of air, open all zone and loop ball valves. Water should continue to be flowing through the system. Quickly close both of inlet ball valves on the ball drain valves. Turn off the pump. The low temperature air purge is now complete.

To purge the boiler side, reverse the flow of the drain valves 3-way ball valves as noted on the second purge/fill diagram. **Make sure any air vent on the**

**boiler is closed.** Plug in the submersible pump and slowly open both inlet ball valves on the ball drain valves. Water should now flow through the boiler and return water and air to the bucket. When the return line is free of air bubbles, quickly close both inlet ball valves on the ball drain valves. Turn off the pump. The system is now purged of air.

Disconnect the purge line and replace the drain valves caps. Position the drain valves 3-way ball valves to the flow through position. Loosen the cap on the air eliminator vent and open any vent on the boiler. Open the supply water ball valve. A small amount of water will be added to increase the system pressure to 15 to 20 psi. The system is now completely filled.

## **9. Connect thermostat and boiler control wiring.**

Open the green control box. At the top right is a terminal strip label with zone 1, zone 2, etc. Using at least 3-conductor (one conductor is a spare) solid thermostat wire, connect the appropriate zone terminal to the room thermostat. Make sure to route the wires through the rubber grommet(s) at the top of the control box.

At the lower left are the X1 and X2 terminals. These connect to the boiler control circuit. Depending upon local codes additional devices may be wired in series such as a low water cutout, high temp limit switches, etc. Use at least 3-conductor (one conductor is spare) solid thermostat wire to make the connection. Make sure to route the wires through the rubber grommet at the bottom left side of the control box. Replace the control box cover.

## **10. Connect to line voltage.**

Depending upon local codes, this could be as simple as plugging in the attached cord into an outlet or the cord may need to be hardwired into a junction box.

## **11. System start up.**

With the boiler power shut off, activate all of the thermostats. All of the zone circulators should turn on. There may be an initial gurgling noise, but as any remaining air is vented out the air eliminator, the system should be quiet in a couple minutes. Check for leaks. Turn boiler power on. The boiler circulator should turn on and the boiler fire up. Observe temperature and pressure gauges. The water temperature entering the zones will need to be adjusted as designed, never exceed 140 °F to the zones. The system pressure should not increase more than 1 psi.

The water temperature is adjusted on condensing boilers via the boiler electronic interface. See the boiler manufacturer manual for specific instructions.

With non-condensing boilers the water temperature is adjusted on the panel with the 3-way mixing valve. Turning the knob in reduces the temperature and turning the knob out increases the outlet temperature. Make adjustments slowly to let the system adjust.

**Congratulations!**

**Your system is now complete and ready for many years of trouble-free operation.**

If you have any questions or need with the installation visit our website

[www.getfloorheat.com](http://www.getfloorheat.com) or call 888-265-5444.



# Appendix

## HYDRONIC PIPING SCHEMATIC

1-4 ZONE, PRIMARY/SECONDARY  
3 ZONE SHOWN

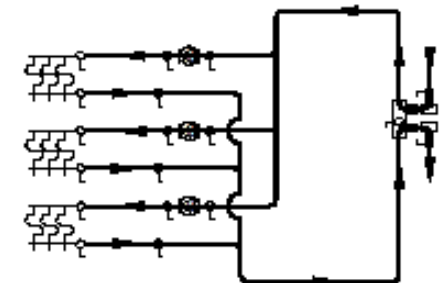
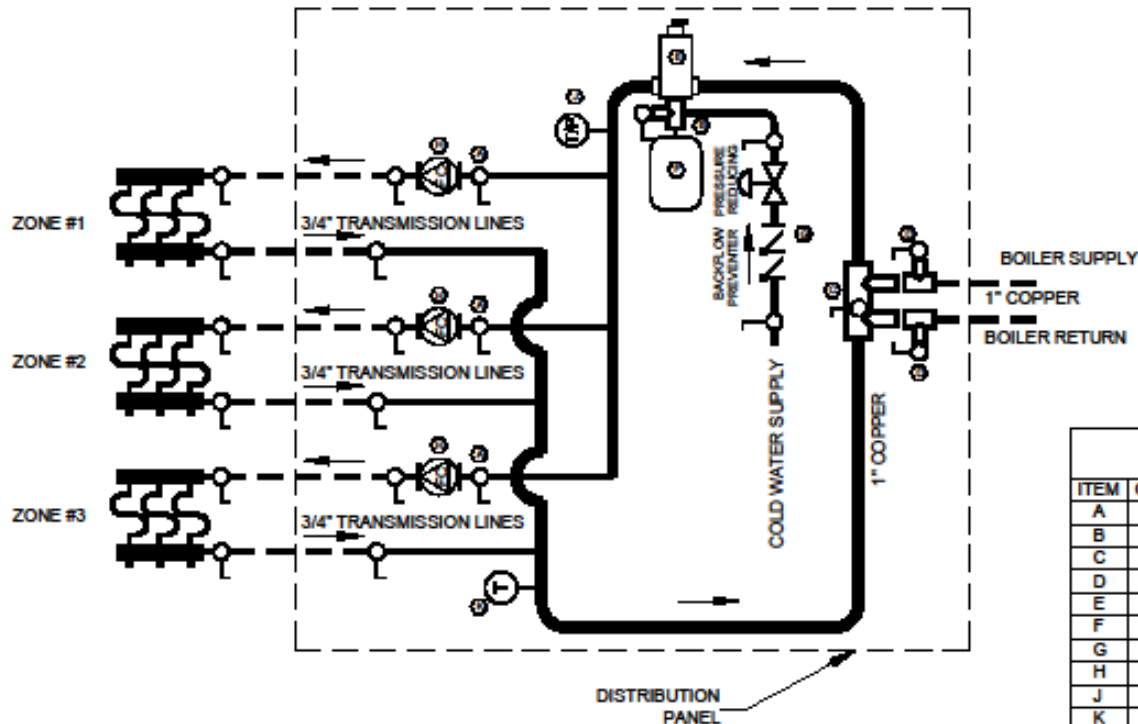

SECONDARY PURGE/FILL DIAGRAM



PRIMARY PURGE/FILL DIAGRAM

### BOM

ITEM	QTY	DESCRIPTION	PART NO.
A	X*	3/4" SWEAT ISOLATION FLANGE KIT	50403
B	1	EXPANSION TANK VALVE	41672
C	1	1" X 1" SWEAT PURGE TEE	58644
D	2	1" SWEAT BALL DRAIN VALVE	50614
E	1	1" SWEAT AIR ELIMINATOR	PV100S
F	1	TYPE #30 EXP TANK	102-1
G	1	1/2" SWEAT COMBO FILL/BACKFLOW	B 911S
H	X*	CIRCULATOR	UPS15-58FC
J	1	TEMP/PRESS GAUGE	TD-090
K	1	TEMP GAUGE	GT162

\* X - THE NUMBER OF ZONES

Designed for:	Floorheat Company
Designed by:	Mike Huhn
Date:	February 21, 2014
Revised:	-

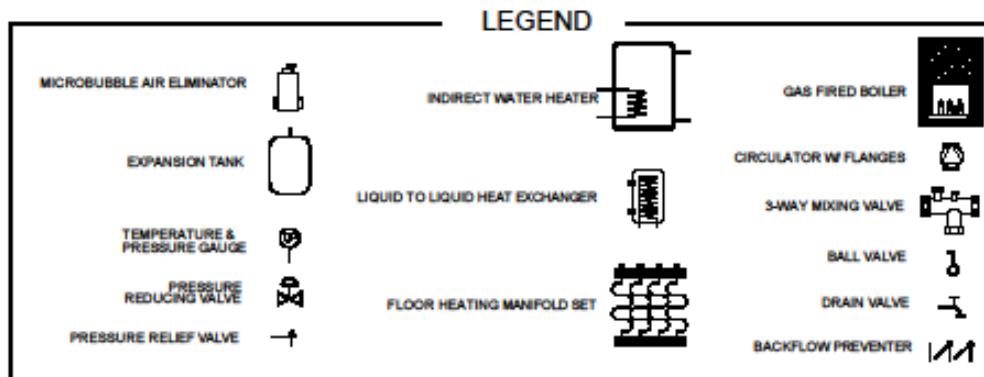

**The FloorHeat Company**  
EASYFLOOR™ SYSTEM

# HYDRONIC PIPING SCHEMATIC

5-8 ZONE, PRIMARY/SECONDARY  
5 ZONE SHOWN

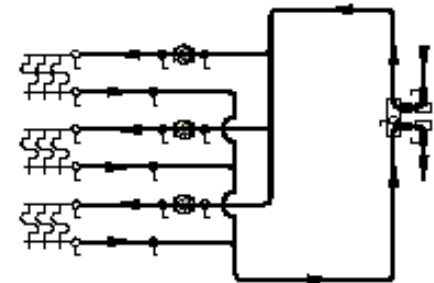
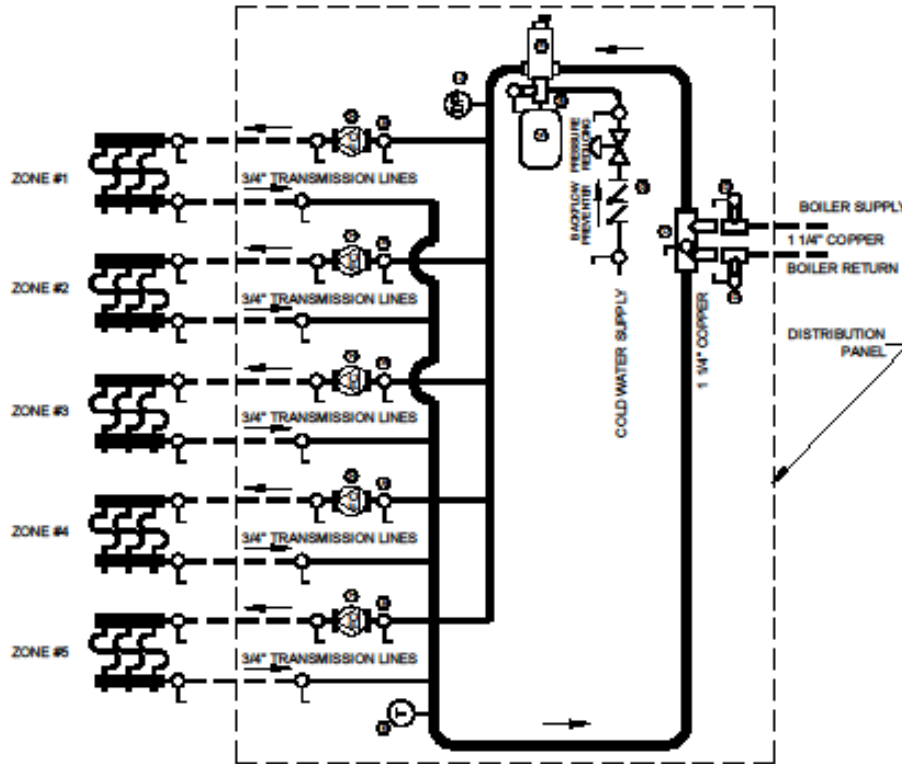

SECONDARY PURGE/FILL DIAGRAM



PRIMARY PURGE/FILL DIAGRAM

## LEGEND

MICROBUBBLE AIR ELIMINATOR



INDIRECT WATER HEATER



GAS FIRED BOILER



EXPANSION TANK



LIQUID TO LIQUID HEAT EXCHANGER



CIRCULATOR W/ FLANGES



TEMPERATURE & PRESSURE GAUGE



3-WAY MIXING VALVE



PRESSURE REDUCING VALVE



FLOOR HEATING MANFOLD SET



BALL VALVE



PRESSURE RELIEF VALVE



DRAIN VALVE



BACKFLOW PREVENTER



## BOM

ITEM	QTY	DESCRIPTION	PART NO.
A	X*	3/4" SWEAT ISOLATION FLANGE KIT	50403
B	1	EXPANSION TANK VALVE	41672
C	1	1 1/4" X 1 1/4" SWEAT PURGE TEE	58655
D	2	1 1/4" SWEAT BALL DRAIN VALVE	50615
E	1	1 1/4" SWEAT AIR ELIMINATOR	PV125S
F	1	TYPE #30 EXP TANK	102-1
G	1	1/2" SWEAT COMBO FILL/BACKFLOW	B 911S
H	X*	CIRCULATOR	UPS15-58FC
J	1	TEMP/PRESS GAUGE	TD-090
K	1	TEMP GAUGE	GT162

\* X - THE NUMBER OF ZONES

Designed for:	Floorheat Company
Designed by:	Mike Huhn
Date:	February 24, 2014
Revised:	-

**The FloorHeat Company**  
EASY FLOOR™ SYSTEM

5-8 Zone Control Panel for Condensing Boiler

# HYDRONIC PIPING SCHEMATIC

1 - 4 ZONE, PRIMARY/SECONDARY  
3 ZONE SHOWN

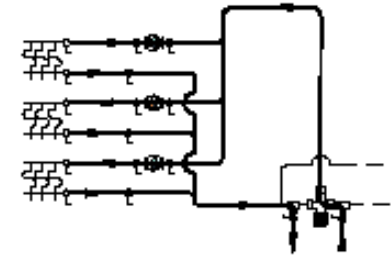
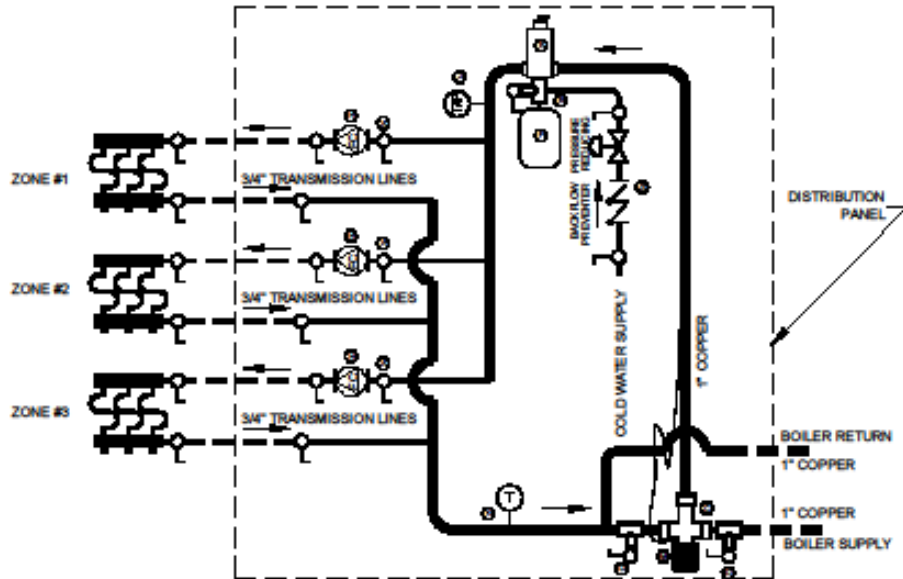

LOW TEMP LOOP PURGE/FILL DIAGRAM

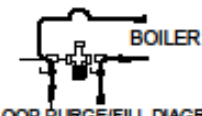

BOILER LOOP PURGE/FILL DIAGRAM

## BOM

ITEM	QTY	DESCRIPTION	PART NO.
A	X*	3/4" SWEAT ISOLATION FLANGE KIT	50403
B	1	EXPANSION TANK VALVE	41672
C	1	1" SWEAT UNION MIXING VLV	V135A1012
D	2	1" SWEAT BALL DRAIN VALVE	S0614
E	1	1" SWEAT AIR ELIMINATOR	PV100S
F	1	TYPE #30 EXP TANK	102-1
G	1	1/2" SWEAT COMBO FILL/BACKFLOW	B 911S
H	X*	CIRCULATOR	UPS15-58FC
J	1	TEMP/PRESS GAUGE	TD-090
K	1	TEMP GAUGE	GT162
M	1	MIXING VLV ACTUATOR (86 - 158 F)	T100R1012

\* X - THE NUMBER OF ZONES

Designed for:	Floorheat Company
Designed by:	Mike Huhn
Date:	February 24, 2014
Revised:	-

## LEGEND

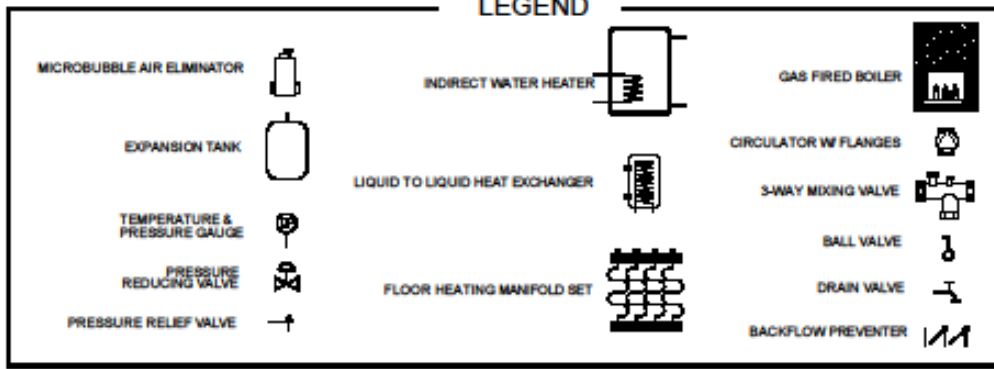

**The FloorHeat Company**  
EASY FLOOR™ SYSTEM

1-4 Zone Control Panel for Non-Condensing Boiler

# HYDRONIC PIPING SCHEMATIC

5-8 ZONE, PRIMARY/SECONDARY  
5 ZONE SHOWN

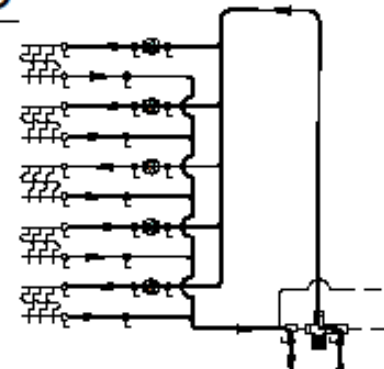
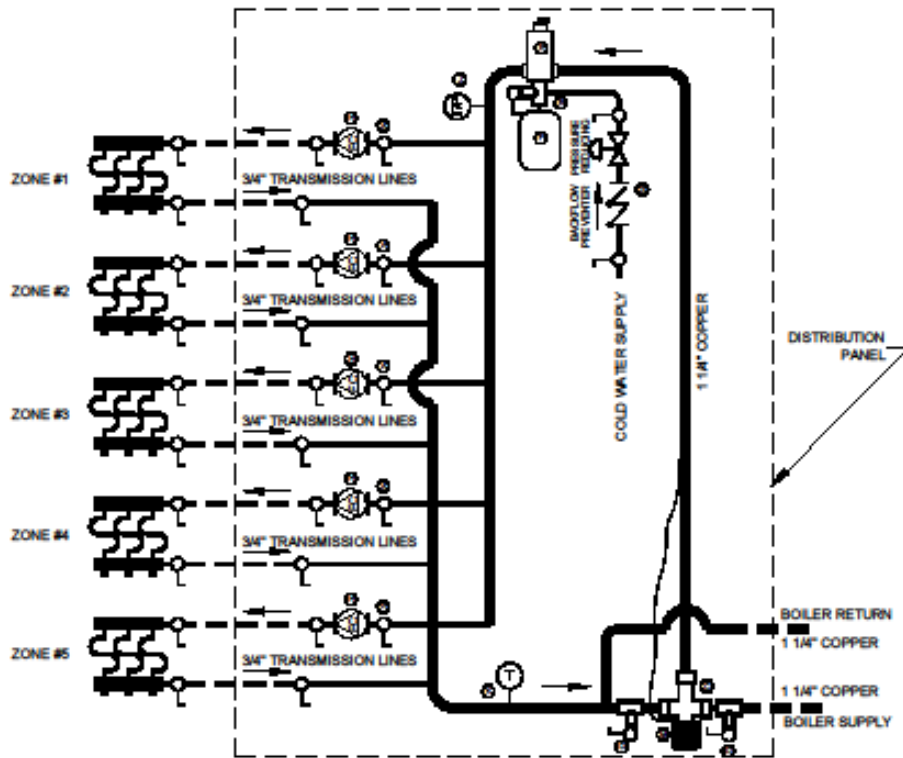

LOW TEMP LOOP PURGE/FILL DIAGRAM

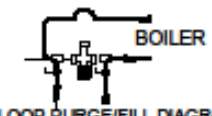

BOILER LOOP PURGE/FILL DIAGRAM

## BOM

ITEM	QTY	DESCRIPTION	PART NO.
A	X*	3/4" SWEAT ISOLATION FLANGE KIT	50403
B	1	EXPANSION TANK VALVE	41672
C	1	1 1/4" SWEAT UNION MIXING VLV	V135A1022
D	2	1 1/4" SWEAT BALL DRAIN VALVE	S0615
E	1	1 1/4" SWEAT AIR ELIMINATOR	PV125S
F	1	TYPE #30 EXP TANK	102-1
G	1	1/2" SWEAT COMBO FILL/BACKFLOW	B 911S
H	X*	CIRCULATOR	UPS15-58FC
J	1	TEMP/PRESS GAUGE	TD-090
K	1	TEMP GAUGE	GT162
M	1	MIXING VLV ACTUATOR (86 - 158 F)	T100R1012

\* X - THE NUMBER OF ZONES

Designed for:	Floorheat Company
Designed by:	Mike Huhn
Date:	February 24, 2014
Revised:	-

## LEGEND

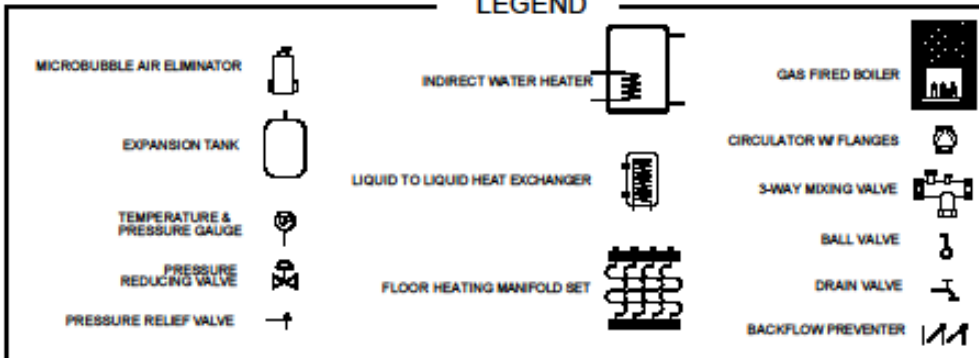

**The FloorHeat Company**  
EASY FLOOR™ SYSTEM

5-8 Zone Control Panel for Non-Condensing Boiler