

Carbon Heating Film

- Easy to install.
- Can be used as a sole room heating source (when covers at least 70% of the floor).
- Does not circulate pollutants, dust, dirt, allergens or dry air.
- May be installed on wall, ceiling, under laminate, engineered wood floors or tile.
- Brings soothing warmth to specific rooms or cold areas.
- Reduces energy up to 60% compared to forced air heating systems.
- Maintenance free, strong and durable.
- Complements your home heating system making rooms more comfortable.

Read through this entire manual before starting installation.

- All electrical connections must be made by a licensed electrician in accordance with national and local codes and standards.
- Always join multiple heating film lines in parallel **ONLY** (never in series).
- Always make sure to check the heating film before, during, and after installation of the floor covering.
- Each thermostat requires a dedicated circuit at the breaker box.
- Must not be installed in damp or wet areas as defined by the National Electrical Code.
- Do not fold or wrinkle the heating film, walk on it unnecessarily, or drop heavy or sharp objects on it.
- Never overlap the heating film.
- Do not install electrical wires or pipes in the floor with the film.
- Be sure underlayment contains no cellulose.
- Install film only when room temperature is above freezing.
- Leave a 6-inch space between film and fireplaces, chimneys, or hot water pipes.
- Never use any type of insulation material on top of the heating film.
- Do not install the heating mats directly over a foil backed insulation material.
- When installing carpet a low tog underlay should be installed followed by a good quality hessian backed carpet.

Failure to follow these instructions may result in fire, electrical shock, property damage, personal injury, or death.

The list of necessary materials before starting the installation of floor heating:

1. Infrared heating film standard width of 19 3/4" (50 cm), 31 1/2" (80 cm) or 39 3/4" (1m);
2. Electrical wire. US standard:
 - a) 12AWG, Stranded, THHN (to make connections from thermostat to heating film);
 - b) 12-2 NM cable (to make connection from thermostat to breaker);For Europe and other countries: recommended parameters of conductors: Copper - section - not less than 1.5 mm²;
3. Clamp Connectors and Mastic insulator.
4. Floor Insulation material. Using a heat insulator with a metallic coating is not recommended;
5. Plastic film thickness of not less than 0.1 mm, to use as vapor barrier (Blue Hawk 10-ft x 25-ft x 4-mil Clear Consumer Sheeting)
6. Scotch-tape;
7. Thermostat with temperature sensor.

List of required tools before starting the installation of floor heating:

1. Screwdriver;

2. Pliers;
3. Scissors;
4. Knife assembly;
5. Wire cutters;

Installing Underfloor Heating Film.

1. Layout of electric underfloor heating systems

Sketch a plan showing how the film will be installed. In drawing up a plan, should take into account that the organization of the main floor heating is necessary to cover at least 70% of the usable space. Do not install film under built-in cabinets, stationary design elements, appliances, in small closets (walk-ins are okay), or under other structures that do not have air circulation space under them. To arrange comfortable heating it must be covered for at least 40% of the surface area.

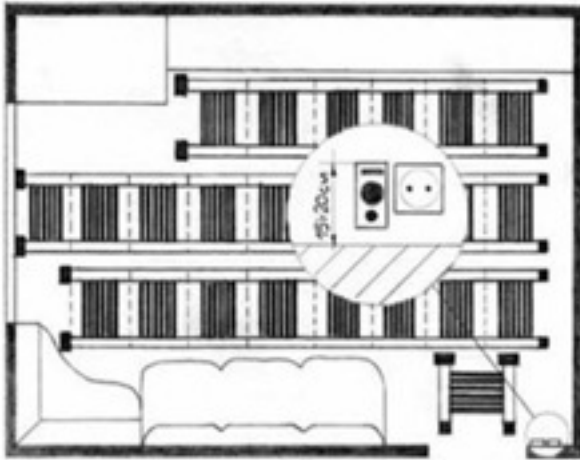

Leave a space and padding around the perimeter of the room size from 4"-8" (10 to 20 cm) spacing between the strips of film - not more than 2" (5 cm) and no less than 1/2" (1cm)

Not allowed: overlapping film on a film

When planning the placement, should take into account that the heating film is cut into sections at designated places specially designed for cutting. The length of a single section is 9 7/8" (24.85 cm).

2. Calculations capacity of the heating system, as well as the definition of the required number of thermostats and electrical power capabilities

The maximum power consumption of infrared heating film is $220W \pm 10\% = 242 W/m^2$. Given this fact and

the amount of space covered by heating film, electrical current can be calculated by the following formula:

$$I = P/U,$$

Where: I - Current;

P - Required heating capacity;

U - Voltage.

The amount of current required for selection of appropriate gauge wiring, and to select the thermostat model.

Consider this calculation on a specific example. For example, the room allocated for installation of floor heating has a total area of 200 sq ft (18.6 sq m), the type of heating - basic flooring - laminate. Excluding the area cluttered with furniture and other design elements, a useful area or the area of the film coating will be 150 sq ft (13.9 sq m).

Heating Film 220V uses 20.5 W and 0.1 Amp per sq ft . 120V uses 20.5W and 0.2 Amp per sq ft

120V System	220V System
75 sq ft x 0.2 Amp = 15 Amp	150 sq ft x 0.1 Amp = 15 Amp
$P = I \times U = 15 \text{ Amp} \times 120\text{V} = 1800 \text{ W} = 1.8 \text{ kW}$	$P = I \times U = 15 \text{ Amp} \times 220\text{V} = 3300 \text{ W} = 3.3 \text{ kW}$
For the thermostat selection it should be guided by the following data: 15 Amp, 1.8 kW = 75 sq ft (6.95 sq m); 27 Amp, 3 kW = 125 sq ft (11.6 sq m)	15 Amp, 3.6 kW = 150 sq ft (13.9 sq m); 27 Amp, 6 kW = 250 sq ft (23.2 sq m)

If the area of the floor heating is larger than presented above, it would be necessary to use more powerful thermostat or use contactor and seek help from qualified professionals.

3. Installation.

Underfloor Heating film for use under wood floor heating and laminate heating is very easy to install and does not require any specialist under floor heating labor or tools, except a qualified electrician to make the final connections to the mains power. When fitting heat film underfloor heating a few simple steps must be followed.

Sweep or vacuum floor to remove any foreign material that could damage the underlayment pad or film. Smooth out any imperfections in the sub floor and remove nails protruding above the surface. The underfloor insulations will not make an unsuitable sub floor suitable for the underfloor heating systems to be installed over.

The first task once the sub floor is ready is laying the 6mm insulation underlay. Role the underfloor insulation out over the sub floor making sure to cover the total floor area where the wood or laminate floor covering is to be installed, not just the underfloor heating area. A contact spray adhesive can be used or a double sided tape to hold the under floor insulation in place and aid the installer if required.



4. Mark out Permanent fixtures

If the location of floor mounted permanent fixtures are known, mark these out to ensure the heating film in not installed under these units.

5. Fitting Underfloor Heating Film.

Laying Heating film is quick and easy. Remove shoes and work in stocking feet when installing film. Be careful not to drop objects on the film. Roll out the film with the bright copper strips facing down. Start at one side of the room rolling out the underfloor heating film from the non-connection end of each line (end with no connection tails), ideally towards the wall the underfloor heating thermostat is located. Each heating film line can be held in place by using a suitable adhesion tape such as duct tape along the ends and side of the film.



Cut out the heating film according to the scheme planned and put on the prepared surface, secure with adhesive tape. Each heating film line can be held in place by using a suitable adhesion tape such as duct tape along the ends and side of the film.



The heating film can be butted together but cannot be overlapped at any time.



6. Underfloor Heating Thermostat Floor Sensor Installation.

Cut a small channel into the underfloor insulation layer to allow the thermostat floor sensor / probe to be laid into, so that the sensor and its wires are below the level of the pad. Run the wire from the sensor to the thermostat and tape it to the pad and the floor. The channel should be located under one of the underfloor heating film. Position the floor sensor under the heating film clear area, not under black carbon heating strips. The floor sensor wire can be extended up to 30' if necessary by splicing comparable gauge, multi-stranded, insulated, electrical wire and waterproofing the splice.





7. Connecting the heating film.

Connecting the heating film strips to the thermostat and electrical connections are made only in a parallel manner.

- a) Strip the insulation from one end of a 12 gauge stranded THHN wire. If the wire is double insulated—be sure to strip both layers of insulation.



- b) Insert the barrel of the connector into the crimping tool so that the “W” of the tool presses on the split side of the barrel. The tool will not release until there is sufficient pressure on the crimp. After crimping, test the wires to be sure they are tight in the connector. If only one wire is to be crimped in the connector, strip 1/2 inch of insulation and double the wire over into a “U” shape before crimping. If two wires are to be crimped together, strip 1/4 inch of insulation from each wire and insert them into the connector together. After crimping, test the wires to

be sure they are tight in the connector.

- c) Place the connector over the copper strip on a corner of the film and crimp it so that the teeth on the connector bite into the copper strip.





- d) The contact points, clamp connectors and free ends of the film insulated by an insulation tape.
- e) Cut 2-inch-wide mastic insulating tape into 2-inch squares. Apply a square of tape to both the top and bottom side of each wire connection and press them together firmly to form a tight seal.



- f) In the same way, use the mastic tape to cover all of the bare ends of each copper strip that do not have wire connections.



- 8. Once the underfloor heating mats have been laid and fixed in place over the floor the connection tails should be run back to the underfloor heating thermostat or junction box location. The diagram below shows the two ways underfloor heating mats can be connected back to the underfloor heating thermostat. (Underfloor heating mats must always be connected in parallel never in series).

● Installation Plan <A-type>

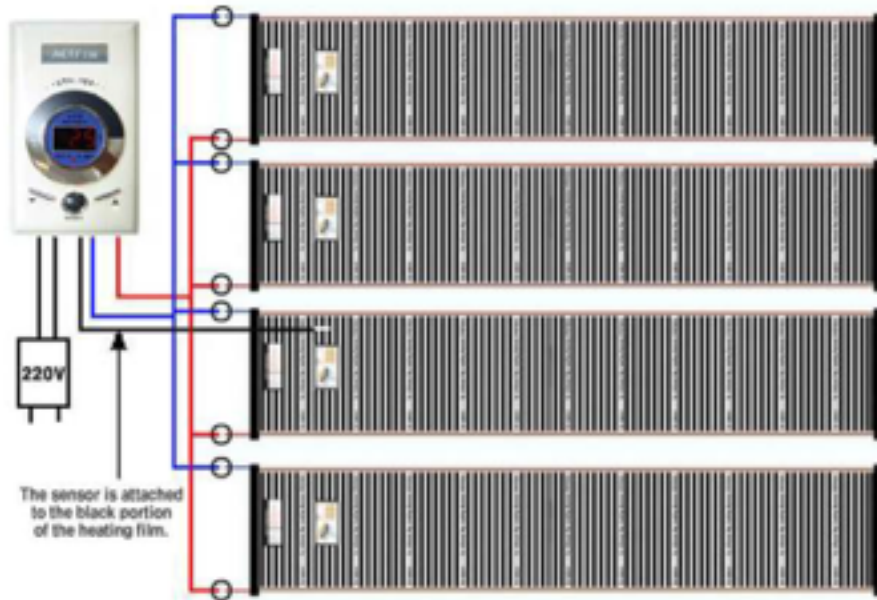

● Installation Plan <B-type>

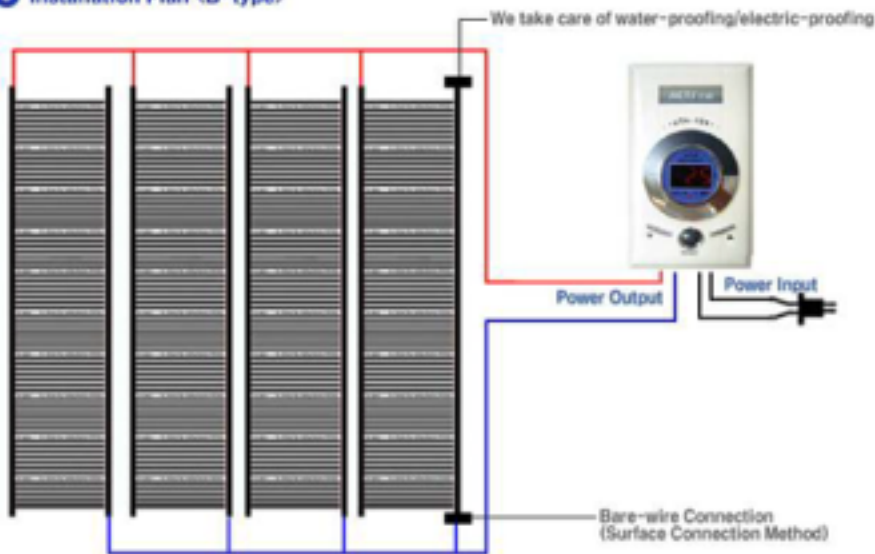

9. The cold ends can be laid in grooves cut in to the insulation for convenience and ease of fitting, the cold ends should not cross under or over the heating film. It is advisable to label and identify the individual cold tails to the heating film for ease of wiring (the heating film do not have a polarity).



The connection ends and cold tails can be pressed into the underfloor insulation by scoring the underfloor insulation and firmly pressing the tails /ends into the scored underfloor insulation. It is advisable to tape over the connection tails and cold ends to keep the underfloor heating mats held in place during the instillation of your wood / laminate floor.



10. Once the underfloor heating film have been laid and fixed in place the vapor barrier is ready to be laid over the top of all the under floor heating film mats. The vapor barrier must fully cover all under floor heating mats. It is not a necessity to cover the whole floor area only the actual underfloor heating film themselves. If necessary the vapor barrier can be taped around the edges to hold it in place.



An electrical test of the adjusted heating film must be carried out by an electrician. All mats must be connected in parallel.



11. Installing a Relay (Contactor)

Depending on the Amperage requirements of multiple **Heating Film lines** (If the circuit allows for more Amperes than the thermostat), a contactor/relay may be required. Heating Film uses 21W and 0.1Amp per sq ft. Consult with an electrician to determine the type and size of contactor/relay required.

The total Amp load of the **Heating Film Lines** must not exceed the thermostat's 18 Amp limit or the Amperage rating of the circuit or other control switch without using an appropriately rated contactor/relay - see (120V contactor circuit) or (240V contactor circuit).

Typical Electrical Wiring Diagram w/contactor & thermostat control (120V)

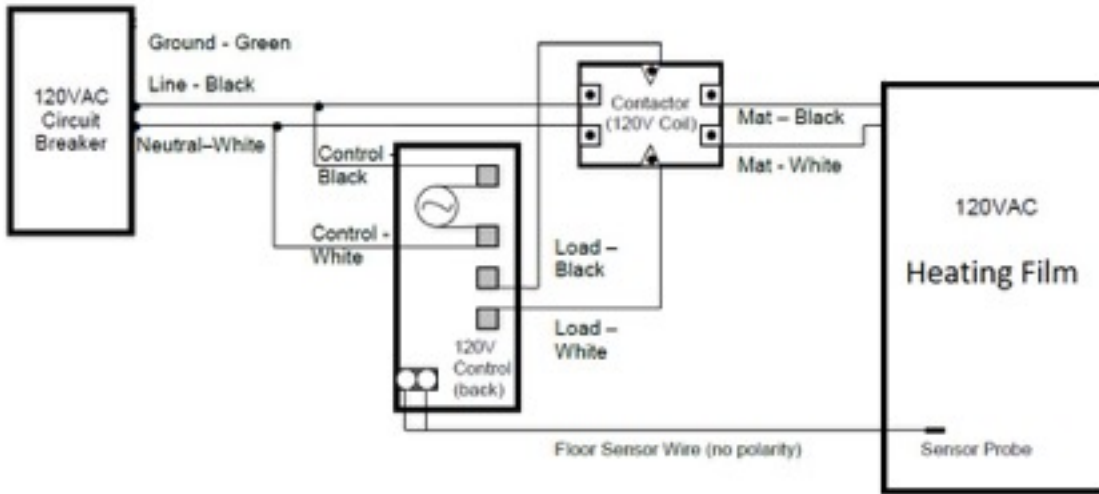

All electrical work must be done by a qualified, licensed electrician in accordance with local building and electrical codes, and the National Electrical Code (NEC), especially Article 424, Part IX of the NEC, ANSI/NFPA 70 and Section 62 of CEC Part I.

Typical Electrical Wiring Diagram w/contactor & thermostat control (240V)

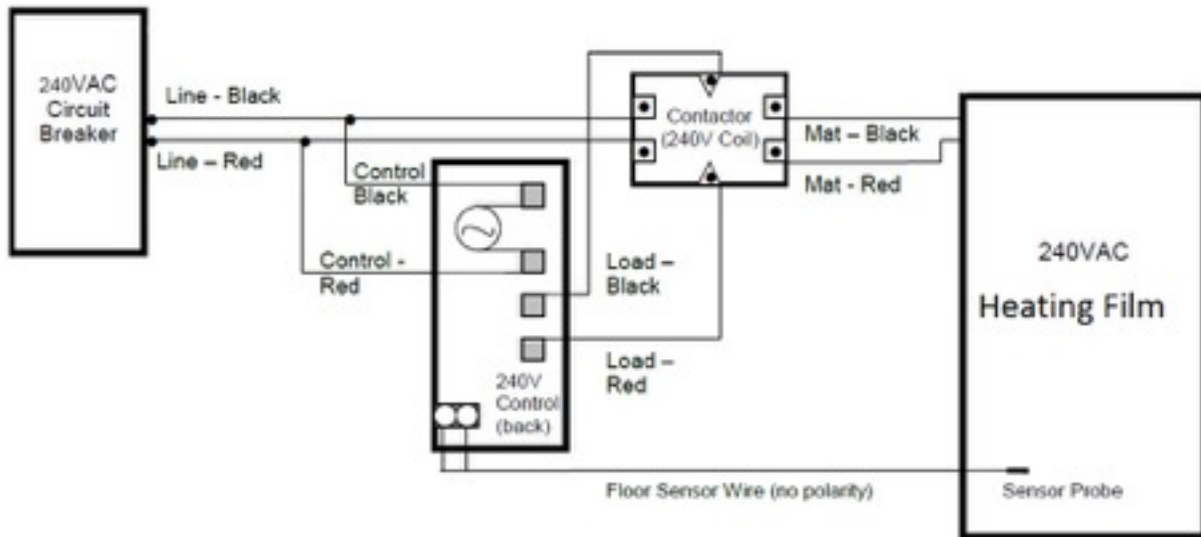

All electrical work must be done by a qualified, licensed electrician in accordance with local building and electrical codes, and the National Electrical Code (NEC), especially Article 424, Part IX of the NEC, ANSI/NFPA 70 and Section 62 of CEC Part I.

A contactor or relay is an electrical device that takes a control signal usually 12 volts DC, or 24, 120, 208-230 volts AC and creates a magnetic field to pull in a set of contacts that controls another device that may or may not get its electrical power from the same circuit.

Contactor is like a switch in the OFF position. When appropriate voltage is applied to the contactor's coil terminals, 'the switch turns itself ON' making the connection between the power supply and the heating system.

In his case the coil voltage is applied by the thermostat calling for the heat.

Contactor is meant to take the load of the control device - a thermostat in this case. Please note how the contacts of the thermostat (where normally the floor heating would be hooked up), are connected to the coil of the contactor and

the contactor is handling the connection between the power source (GRAY wire) and the load of the floor heating mats (4 white cords) in this case.

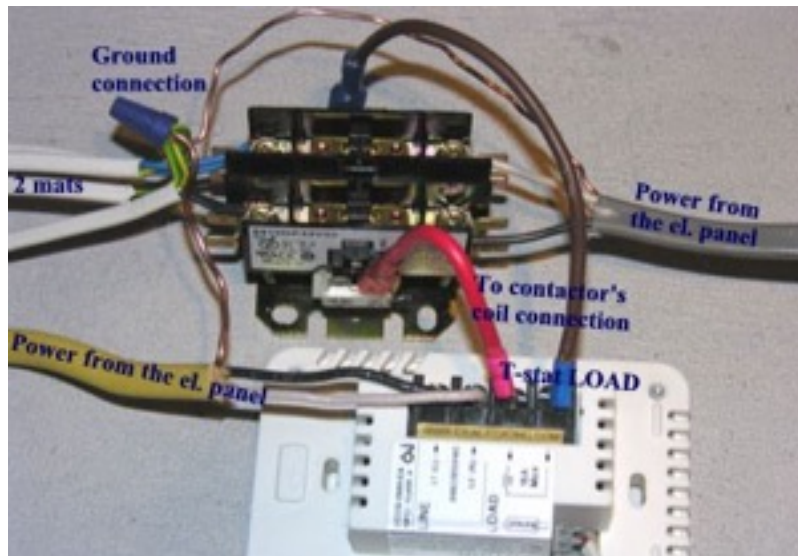

Two parameters of the definite purpose contactors are important:

- Max. Amperage.
- Coil Voltage.

If the thermostat voltage is 120V then the contactor's **coil voltage** HAS TO BE 120V, but the mat(s) can be 240V BUT CONNECTED BY WAY OF A CONTACTOR TO 240V power source. The same can be said about 120V when connected to 120V power - but again - by way of the contactor.

- Contactor's coil voltage has to agree with the device 'driving it', the thermostat in this case.
- Heating Film Lines voltage has to agree with the voltage of the power source regardless of the contactor's coil voltage. Heating Film Lines TOTAL AMPERAGE has to be smaller than the one of the contactor AND THE AMPERAGE OF THE POWER SUPPLY.

Please Note: nothing should be subjected to operation under full load for long periods of time even if allowable by specs.

This said, if the thermostat max. load is 18A, and if the real load from floor heating is 16A or more: USE THE CONTACTOR! Definite purpose contactors are inexpensive and not difficult to connect.

It is normal for the contactor to wear out over time like brake pads on a car. If the contactor shows any signs of wear it should be replaced as a preventative measure or as part of maintenance. The electrical box housing the contactor should be closed. First, because of the safety - there is line voltage present there and also because you can have problems with spiders building nests in the contactor; the silk is an insulator and will prevent electricity from flowing!